

YUEQING HONGYI ELECTRONICS CO., LTD  
乐清市宏一电子有限公司

SPECIFICATION FOR APPROVAL

承认书

CUSTOMER 客户名称	
DESCRIPRION 产品名称	25401 系列连接器
ITEM NO 编 号	HY-A25401 (A77)
DATE 日 期	2022-9-14

CUSTOMER ACKNOWLEDGEMENT SEAL

客户承认印签

(APPROVAL) 核准	(ENGINEERING) 工程	(PURCHASE) 采购	(QUALITY) 品质
承认结果: <input type="checkbox"/> 通过 <input type="checkbox"/> 不通过 <input type="checkbox"/> 重新送样			

IS09001

IS014001

IS045001

IATF16949 体系认证

ADD: No. 30, Wenjing Road, Houyu village, Shifan street, Yueqing City, Zhejiang Province

地此: 浙江省乐清市石帆街道后屿文景路 30 号

TEL:0577-62380521

FAX: 0577-62381979 P.C:325608

http: //www.zhehongyi.com

E-MAIL:yaohongxiao88@126.com

# 产 品 承 认 书 目 录

1、封面	1-1
2、修订履历	2-2
2、目录	3-3
3、技术规范	4-10
4、产品图纸	11-12



# PRODUCT SPECIFICATION

## 产品规范

### 1、Scope

#### 适用范围

This specification includes the following specifications, including the specification of 2.54mm pitch 25401 series connector

本规范包括下列此种规格包括 2.54mm Pitch 25401 系列连接器规格说明

### 2、Appearance and Dimension

#### 外观及尺寸

2.1 Appearance: Product surface without defect、dirt、crack、and mechanical damang, Contact without rust, plating not oxidized and not peeled.

产品表面不应有对制品有害的缺陷、污垢、裂痕及机械损伤；接触件无锈蚀、镀层氧化脱落等现象

2.2 Dimension: According to drawings

外形尺寸：依照附图

### 3、Disposal of Material and surface

#### 材料与表面处理

Specification 规格内容		Material 材质	Finish 表面处理	Environmental protection grade 环保等级
Wafer 母座	Plastic 塑壳	PA66 UL94V-0	Color: White 颜色: 白色	RoHS2.0
	Contact 插针	Phosphor bronze 磷铜厚0.20mm	Tin Plating: 2.5~5 μm 镀锡: 2.5~5 μm	
Wafer 公座	Plastic 塑壳	LCP UL94V-0	Color: Beige 颜色: 米色	
	Contact 插针	Phosphor bronze 磷铜厚0.30mm	Tin Plating: 2.5~5 μm 镀锡: 2.5~5 μm	

#### 4、Ratings and applicable wires

##### 额定等级

Item 项目	Standard 规格
Rated Voltage 额定电压	250V AC/DC
Rated Current 额定电流	1A AC/DC
Ambient temperature Range 使用温度范围	-25℃- +105℃
Applicable wire insulation 适用线径	AWG24#-28#

#### 5、Electrical Performance

##### 电气性能

N0. 序号	Ltem 项目	Test mode 试验方法	Requirement 技术要求
5.1	ContactResistance 接触电阻	Male female cooperation, open voltage less than 20mV, current 100mA detection connector at both ends  公母配合, 开放电压20mV 以下, 电流100mA 检测连接器连接器两端	Initial:20mΩ Max 初始: 20mΩ Max  After Test: 30mΩ Max 试验后: 30mΩ Max
5.2	withstandvoltage 耐电压	Mate connectors, apply 800V AC for 1 minute between adjacent terminal or ground  公母配合, 在相邻端子, 端子与地片之间, 使用800V 的交流电1 分钟, 检测连接器	No Breakdown and Flashover  外观无损伤, 无打火花
5.3	InsulationResistance 绝缘电阻	Mate connectors, apply 500V DC between adjacent terminal or ground  公母配合, 在相邻端子, 端子与地片之间, 使用500V 的直流电, 检测连接器	1000MΩ Min

## 6、机械性能

### Mechanical Performance

N0. 序号	Ltem 项目	Test mode 试验方法	Requirement 技术要求
6.1	Terminal/ Housing Retention Force 端子保持力	Apply axial pull out force at the speed rate of $25.4 \pm 3 \text{mm/minute}$ on the terminal assembled in the Housing 以每分 $25.4 \pm 3 \text{mm}$ 的速率, 将端子从 Housing 内轴向拔出力	Per contact: 10N Min 单一接触点: 10N Min
6.2	Insertion & withdraw Force 插拔力	Insert and withdraw Connectors at the speed rate of $25.4 \pm 3 \text{mm/minute}$ 以每分 $25.4 \pm 3 \text{mm}$ 的速率插入和拔出	Refer to paragraph 8 参照第 8 项
6.3	Pin Retention Force Pin 针保持力	Apply axial push force at the speed rate of $25.4 \pm 3 \text{mm/minute}$ 以每分 $25.4 \pm 3 \text{mm}$ 的速率, 将 PIN 针从 Wafer 内轴向拔出力	Per contact: 10N Min 单一接触点: 10N Min

## 7、Endurance Characteristics:

### 环境性能

N0. 序号	Ltem 项目	Test mode 试验方法	Requirement 技术要求	
7.1	Repeated Insertion/ Withdrawal 重复插拔	When mated up to 30 cycles repeatedly by the rate of 10 cycles per minute 以每分不超过 10 次的速率, 将公母插拔 30 次	Contact Resistance 接触电阻	30 mΩ Max
7.2	Temperature Rise 温升测试	Mating connectors shall be energized at rating current until thermal stability is achieved, and then measured the temperature rise 公母连接器配合后, 加载额定电流直到温度上升到稳定状态, 然后再测量温升	Temperature Rise 温升测试	30°C Max
7.3	Vibration test 振动测试	Amplitude: 1.5mm P-P Sweep time: $10 \sim 55 \sim 10 \text{ Hz}$ in 1 minute Duration: 2 hours in each X.Y.Z axials 振幅: 1.5mm P-P 时间: $10 \sim 55 \sim 10 \text{ Hz}$ in 1 minute 持续时间: 每轴向 2 小时	Appearance 外观	No damage 无异常
			Contact Resistance 接触电阻	30 mΩ Max
			Discontinuity 瞬断	1 micro-second Max.

NO. 序号	Ltem 项 目	Test mode 试验方法	Requirement 技术要求	
7.4	Heat Resistance 耐热性	105±2℃,96 hours	Appearance 外观	No damage 无异常
			Contact Resistance 接触电阻	30 mΩ Max
7.5	Cold Resistance 耐寒性	-25±3℃,96 hours	Appearance 外观	No damage 无异常
			Contact Resistance 接触电阻	30 mΩ Max
7.6	Humidity 耐湿性	Temperature: 60±2℃ Relative Humidity: 90~95% Duration: 96 hours  温度: 60±2℃ 湿度: 90~95%(RH) 持续时间: 96 hours	Appearance 外观	No damage 无异常
			Contact Resistance 接触电阻	30 mΩ Max
			Withstand Voltage 耐电压	No Breakdown and Flashover 外观无损伤, 无打火花
			Insulation Resistance 绝缘电阻	100MΩ Min
7.7	温度变化 Temperature Cycling	5 cycles of: a) -25℃ 30 minutes b) +105℃ 30 minutes  从-25℃持续30 分钟升至+105℃持续30 分钟, 循环5 次	Appearance 外观	No damage 无异常
			Contact Resistance 接触电阻	30 mΩ Max
7.8	Salt spray 盐雾	24±1 hours exposure to a salt spray from the 5±1% solution at 35±2℃  在温度35±2℃, 盐水浓度5±1%下, 盐水喷 雾24±1 小时	Appearance 外观	No damage 无异常
			Contact Resistance 接触电阻	30 mΩ Max
7.9	Solderability 焊锡附着性	Soldering Time: 3-5sec solder Temperature: 245±5℃  焊接时间: 3-5 秒 焊接温度: 245±5℃	Solder Wetting 焊料润湿	Immersion area above 95%  浸渍面积 95% 以上

NO. 序号	Ltem 项 目	Test mode 试验方法	Requirement 技术要求	
7.10	Solder- Resistance 焊锡耐热性	<p>SMT reflow soldering heat resistance range: Soldering time:5~10sec solder. Temperature:255±5℃ SMT 型回流焊接耐热范围: 焊接时间: 5~10 秒. 焊接温度: 255±5℃</p> <p>Please refer to the 9.1 solder reflow temperature curve 回流焊请参考 9.1 温度曲线图</p>	Appearance 外观	No damage 无异常



## 8、INSERTION/WITHDRAWAL FORCE

## 综合插入力及拔出力

No. of CTK PIN 数	At Initial 初始值		At 30th 插拔 30 次	No. of CTK PIN 数	At Initial 初始值		At 30th 插拔 30 次
	I. F (N Max) 插入力	W. F (N Min) 拔出力	W. F (N Min) 拔出力		I. F (N Max) 插入力	W. F (N Min) 拔出力	W. F (N Min) 拔出力
4	30	2.0	1	24	90	7.0	6.0
6	35	2.5	1.5	26	100	7.5	6.5
8	40	3.0	2.0				
10	45	3.5	2.5				
12	50	4.0	3.0				
14	55	4.5	3.5				
16	60	5.0	4.0				
18	65	5.5	4.5				
20	70	6.0	5.0				
22	80	6.5	5.5				

## 9、 SMT lead-free process temperature curve SMT 无铅工艺温度曲线

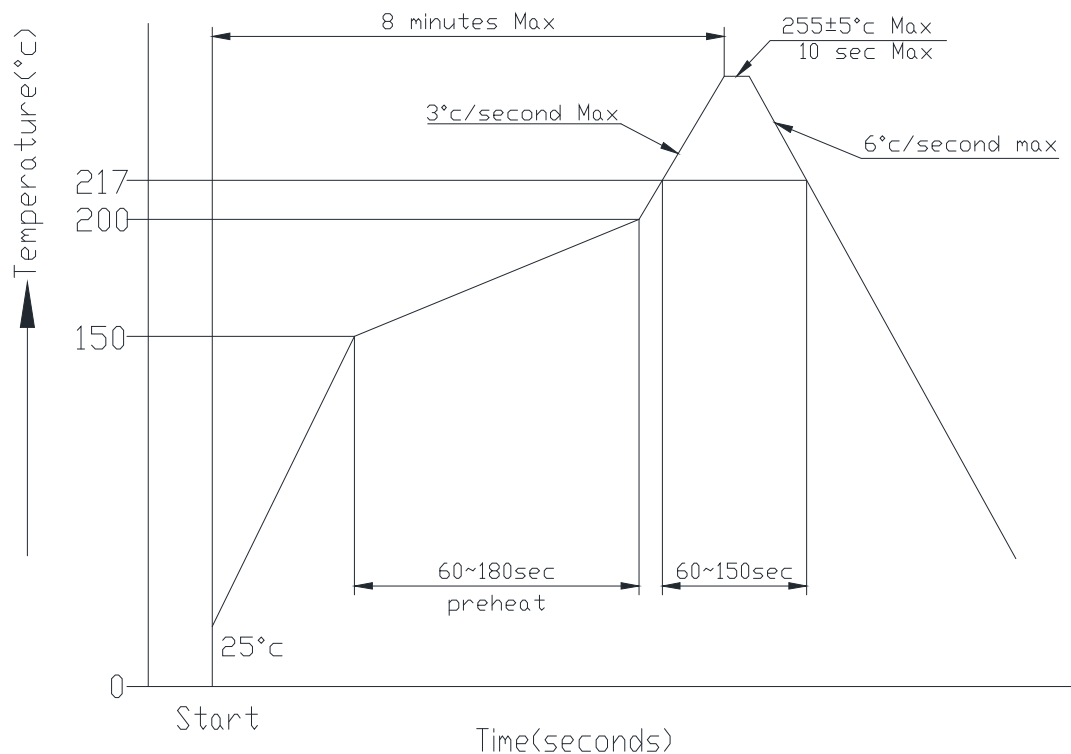

Notes: Please check the reflow soldering condition by your own devices beforehand. Because the condition changes by the soldering devices, P.C. boards, and so on

注记: 由于 P.C 板等焊接装置改变条件,所以请预先用自己的装置检查回流焊的条件

## 10、 Caution 注意事项

plastic because of characteristics with water after package is opened should avoid exposure to, the temperature is higher than 30 °C, humidity is higher than 60%RH in the environment, and in the 24 hours after all after use, to prevent subsequent reflow, wave soldering process to produce foaming phenomenon of deformation

塑料因具有吸水之特性包装拆封后应避免暴露于, 温度高于 30°C, 湿度高于 60%RH 的环境中, 并在拆封后 24 小时内全数使用完毕, 防止后续回流焊、波峰焊制程产生起泡变形现象

版本 REV.	日期 DATE	ECN NO.	变更内容 DESCRIPTION	制图 DRAWN

**SPECIFICATIONS**

- 1、Current Rating: 1A AC, DC
- 2、Voltage Rating: 250V AC, DC
- 3、Temperature Range: -25°C~+105°C
- 4、Contact Resistance: 20mΩ Max
- 5、Insulation Resistance: 1000MΩ Min
- 6、Withstanding Voltage: 800V AC/minute
- 7、Material  
Wafer: PA66 UL94V-0  
PIN: Phosphorous copper Tin-plated

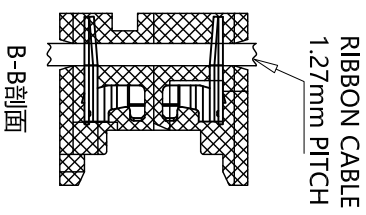
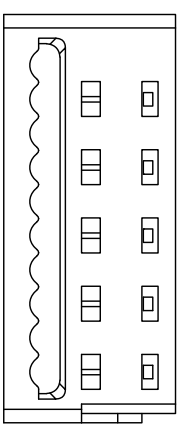
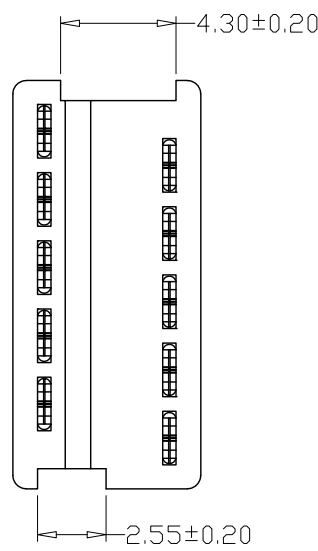
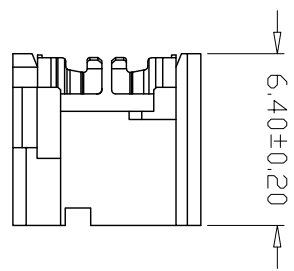
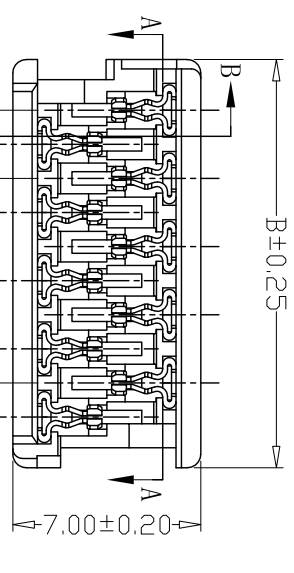
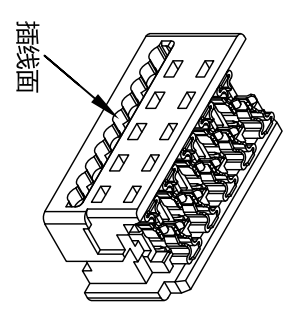
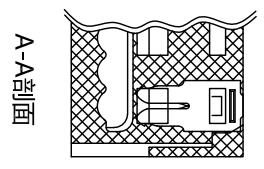
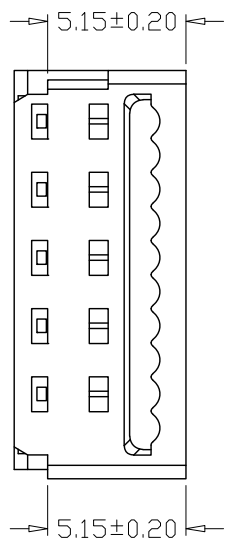

PIN	尺寸 (mm)	
	A	B
04Y	3.81	7.59
06Y	6.35	10.13
08Y	8.89	12.67
10Y	11.43	15.21
12Y	13.97	17.75
14Y	16.51	20.29
16Y	19.05	22.83
18Y	21.59	25.37
20Y	24.13	27.91
22Y	26.67	30.45
24Y	29.21	32.99
26Y	31.75	35.53

GENERAL TOLERANCE		制图 Mapping	张迎春	料号 PART NO.	A25401-nY	版本 REV.	A
X $\pm$ 0.25	X $\pm$ 2°	审核 Audit	钱岳生	品名 TITLE	25401母座	页次 SHEET	1/1
X $\pm$ 0.25	X $\pm$ 1°	核准 Approved	张名	客户料号 CSTM. NO.			
.XX $\pm$ 0.15	.XX $\pm$ 0.5°	单位 Units	2022.09.14	比例 SCALE	1:1		
.XXX $\pm$ 0.10	.XXX $\pm$ 0.5°						

乐清市宏一电子有限公司  
YueDing HongYi Electronics Co., Ltd

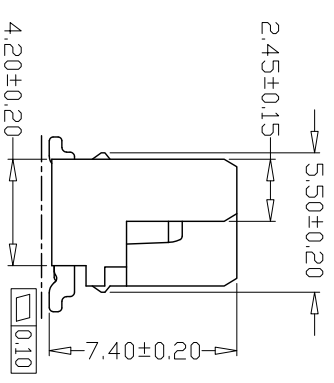
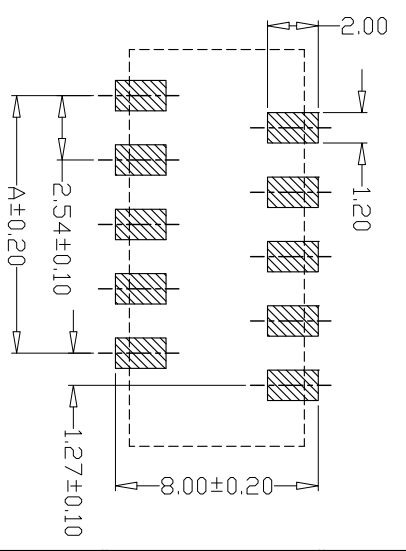
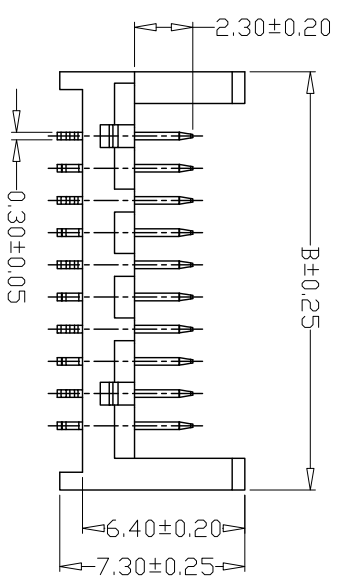
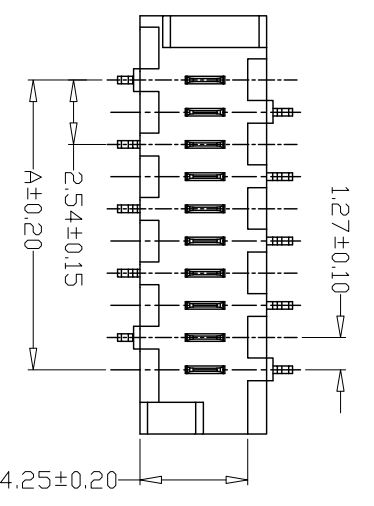
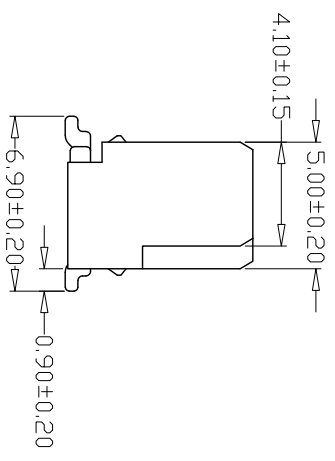
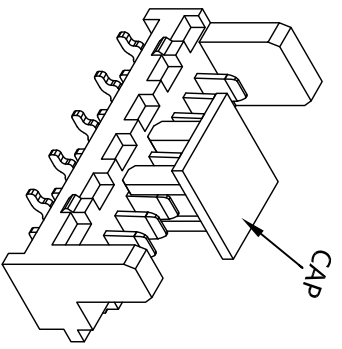

PCB LAYOUT

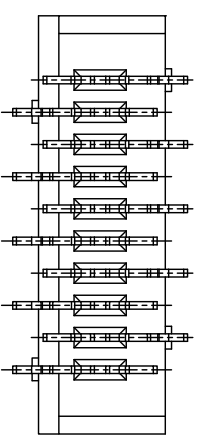

PIN	尺寸 (mm)	
	A	B
04AB	3.81	8.86
06AB	6.35	11.40
08AB	8.89	13.94
10AB	11.43	16.48
12AB	13.97	19.02
14AB	16.51	21.56
16AB	19.05	24.10
18AB	21.59	26.64
20AB	24.13	29.18
22AB	26.67	31.72
24AB	29.21	34.26
26AB	31.75	36.80

SPECIFICATIONS

- 1、Current Rating: 1A AC, DC
- 2、Voltage Rating: 250V AC, DC
- 3、Temperature Range: -25°C~+105°C
- 4、Contact Resistance: 20mΩ Max
- 5、Insulation Resistance: 1000MΩ Min
- 6、Withstanding Voltage: 800V AC/minute
- 7、Material  
Wafer: LCP UL94V-0  
PIN: Phosphorous copper Tin-plated

GENERAL TOLERANCE		制图 Mapping	张迎春	料号 PART NO.	A25401-nAB	版本 REV.	A
X <sub>±0.25</sub>	X <sub>±2°</sub>	审核 Audit	钱岳生	品名 TITLE	25401 贴片电容	页次 SHEET	1/1
X <sub>±0.25</sub>	X <sub>±1°</sub>	核准 Approved	张名	客户料号 WAREH. SMT TYPE			
.XX <sub>±0.15</sub>	.XX <sub>±0.5°</sub>	单位 Units	2022. 09. 14	客户料号 CUTL. NO.			
.XXX <sub>±0.10</sub>	.XXX <sub>±0.5°</sub>	MM SCALE	1:1				



1 2 3 4 5 6 7 8 9

A B C D E F